

# **HALCO**

## **Installation, Operation and Maintenance Instructions For HALCO 2500 SUPREME PUMPS**

HAL OILFIELD PUMP & EQUIPMENT, INC.  
11300 WINDFERN  
HOUSTON, TEXAS 77064  
PHONE 281-517-3100  
FAX 281-517-0350  
EMAIL [halco@haloil.com](mailto:halco@haloil.com)  
WEB SITE <http://www.haloil.com>

### **Table of Contents Introduction General Instructions**

#### **PART I Installation**

- Interchangeability
- Location
- Foundation
- Coupling Alignment
- Piping (General)
- Piping (Suction)
- Piping (Discharge)

#### **PART II Preparation For Operation**

- Initial Lubrication
- Mechanical Seals
- Check Pump Rotation
- Packed Pumps
- Mechanical Seal Pumps
- Priming The Pump
- Start-Up Checklist

#### **PART III Operation**

- Maximum Operating Conditions
- Pump Records
- Bearing Lubrication
- Lip Seal Lubrication
- Packing Lubrication

#### **PART IV Maintenance**

- Disassembly
- Inspection
- Assembly
  - A. Shaft and Bearing Sub-Assembly
  - B. Power Frame Sub-Assembly
  - C. Assembly Of The Fluid End To The Power Frame
  - D. Packing The Pump
  - E. Mechanical Seal Assembly
- Excessive Packing Leakage and Rapid Packing Wear
- Installing Water Flush System To Be Compatible With Oil Companies
- Bearing Failures and How To Improve Bearing Life.

#### **PART V Miscellaneous Information**

- Suction Line Velocity
- Net Positive Suction Head (NPSH)
- Capacity Limits of Pumps
- Capacity Requirements of Rig Equipment
- Long Term Storage

## **Introduction**

This manual contains instructions for the installation, operation, and maintenance of the **HALCO 2500 SUPREME** Pump. As pump service conditions and specifications vary considerably in pump installation, this manual cannot possibly cover every situation, but it is hoped that the information included will serve as a guide. Should questions arise, or start-up problems occur, it is suggested that you contact the HALCO Pump Distributor or Salesman in your area.

The **2500 SUPREME** pump generation is an improved version of older 2 ½ inch shaft pumps. The **2500 SUPREME** pump is designed to give longer service life through a wear pad replacement casing, oil bearing lubrication, stainless shaft and stainless casing nuts.

There are many principles of proper pump installation and application as well as special considerations for the **2500 SUPREME** design which, if followed, will further enhance the performance of your **2500 SUPREME** pump.

This document will deal with both general and specific recommendations for improved **2500 SUPREME** performance in both oilfield and industrial applications.

## **General Instructions**

1. Operate the pump only in the performance range for which it was designed.
2. The pump driver must drive the pump **CLOCKWISE** when viewed from the coupling end. Reversing the rotation will damage the pump.
3. Do not operate the pump with the suction or discharge valves closed.
4. Adjust the packing so that a small amount of leakage remains for lubrication and cooling.
5. When operating in drilling mud, prevent packing drippage from clogging the drip area and hardening around the slinger and front seal.
6. See Section E for mechanical seal installation.

## **PART I Installation**

### **Interchangeability**

**2500 Supreme** horizontal centrifugal pump outside envelope dimensions are the same

as older 2 1/2 inch pumps of the same nominal size so the models can be interchanged without changing existing piping, couplings, or bases.

### **Location**

The pump should be located near the liquid source so that the suction line can be short and direct. The pump should be located below the level of the liquid to eliminate the necessity of priming.

### **Foundation**

The foundation should be sufficiently rigid and substantial to absorb any vibration and support the base plate at all points. A concrete foundation, poured on a solid footing of adequate thickness to support the pumping unit, provides the most satisfactory foundation. The base plate should be installed in a level position.

**Note: A detailed description of proper procedures for grouting base plates may be found in the Hydraulic Institute Standards, 13<sup>th</sup> Edition, Pages 116,117.**

The rugged design of the frame and fluid end makes the **2500 SUPREME** more tolerant of improper foundations than many other pumps. When fabricated bases or fabricated skid bases are utilized, the foundation should be sufficiently rigid and level to absorb any vibration and support the base at all points.

### **Coupling Alignment**

Good service life of the pump and driver depends upon good alignment through the flexible coupling. If the electric motor was mounted at the factory, the pump and motor were in alignment when shipped. **The alignment between the pump and driver should be inspected after installation to ensure that transportation or other handling has not caused misalignment of the unit.** Poor alignment may cause failure of the coupling, pump, motor, or bearings. **Alignment must not be attempted until the base is in position and the mounting and flange bolts have been tightened.**

The recommended procedure for coupling alignment is with the use of a dial indicator, as illustrated in Figures 1 and 2. The dial indicator is attached to one coupling half

with the indicator button resting on the O.D. of the other coupling half to measure offset misalignment. To measure angular misalignment, the indicator is positioned so that the buttons rest on the face, near the O.D., of the other coupling half. Rotate the shaft and dial indicator one revolution while the other shaft remains stationary and note the T.I.R. Unless otherwise specified by the coupling manufacturer, offset misalignment should be limited to 0.005 inches T.I.R. Adjust the alignment by loosening the pump or driver mounting bolts and retighten or shim as required.

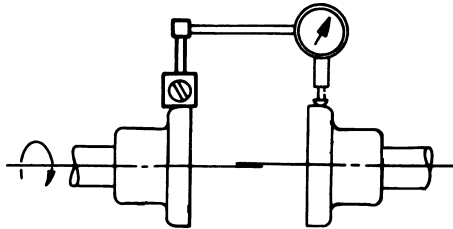

**Figure 1**

Measuring Offset Misalignment With A Dial Gauge

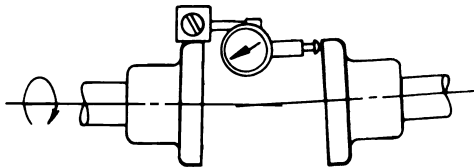

**Figure 2**

Measuring Angular Misalignment With A Dial Gauge

In areas where a dial indicator arrangement is not available, an adequate job of alignment can be done with a straightedge. This method is especially useful if the coupling used contains a rubber drive element.

To check offset misalignment, lay the straightedge in line with the shafts on the O.D.'s of the coupling halves. There should be no gaps under the straightedge. Check two locations 90 degrees apart. Angular misalignment can be checked by measuring the gap between coupling half faces. There should be no more than a 1/64 inch gap under the straightedge or a 1/64 inch

variation in the gap between the coupling halves. See Figures 1A and 2A.

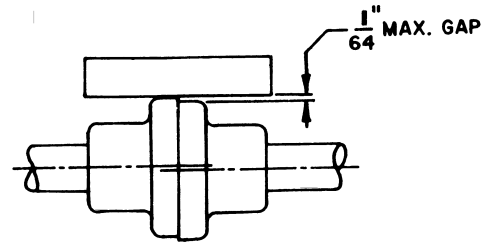

**Figure 1A**

Measuring Offset Misalignment Using a Straightedge

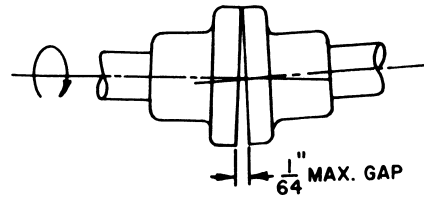

**Figure 2A**

Measuring Angular Misalignment Using A Straightedge

Note: Further reference on coupling alignment can be found in Hydraulic Institute Standards, 13<sup>th</sup> edition, pages 177, 120.

### Piping (General)

Note: Piping must not be connected to the pump until the grout has hardened and the foundation and pump hold down bolts have been tightened.

Piping should be anchored independently of the pump and as near to it as possible. Pipe companion flanges should line up naturally with pump flanges. **Do not draw the pipe to the pump with flange bolts.**

### Piping (Suction)

Properly selected and installed suction piping is extremely important to eliminate vibration and cavitation in the pump. Vibration can cause packing problems, mechanical seal damage, or undue bearing loads.

The suction line should be equal to or larger than the pump suction. **The capacity**

**of a centrifugal pump should never be adjusted by throttling the suction line.**

A positive shut-off valve of a type to cause minimal turbulence should be installed in the suction line to permit the closing of the line for removal of the pump for inspection and maintenance.

The suction line should be designed to eliminate any air pockets. The piping should gradually slope downwards to the supply source to eliminate air pockets.

The suction line should have a straight section into the pump of a length equivalent to at least two times its diameter; i.e. a 4-inch suction line should have a minimum 8-inch straight run.

For temporary hook-up when flexible hose is used, a non-collapsing hose is essential since the suction line pressure is often below atmospheric pressure. A collapsed suction line will result in below average or complete loss of flow.

### **Piping (Discharge)**

A positive shut-off valve should be located in the discharge piping to permit the closing of the line for removal of the pump for inspection and maintenance.

All piping should be independently supported and accurately aligned. **The pump must not support the weight of the pipe or compensate for misalignment.**

If operating conditions are not known with sufficient accuracy, it will be necessary to provide a throttle valve in the discharge line to ensure that the pump operates at the design point.

If the pump is connected to a pressurized system, it is important to install a check valve between the pump discharge and the throttling valve. The check valve will prevent back flow through the pump. Back flow may cause the impeller to become loose on the shaft. A loose impeller will likely result in mechanical damage and fluid leakage beneath the shaft sleeve.

## **PART II PREPARATION FOR OPERATION**

### **Initial Lubrication**

Standard pumps are shipped Grease Lubricated with Chevron Duralith EP#2 Grease. See page 5 for lubrication instructions.

The air vent should be kept clean to prevent pressure build-up due to heating that occurs in normal operation.

Oil lubrication is available upon request. There is a dipstick available that indicates the correct oil level.

### **Mechanical Seals**

When mechanical seals are furnished they are installed and adjusted at the factory. The H22451-1 mechanical seal and the new H25001-1 tungsten carbide mechanical seal normally used in drilling mud environments do not require external flush.

To properly prepare special or industrial mechanical seals for operation, various cooling and flushing flows may have to be connected. Liquid from an outside source may be required. If outside flushing is required, connect the necessary cooling or flushing lines to the seal and be sure they are operating before starting the pump. See seal drawings and instructions if special seals are used.

### **Check Pump Rotation**

Most pumps manufactured have clockwise rotation when viewed from the coupling end. The correct rotation can be found by an arrow on the casing.

It is very important that the pump rotation is determined before starting the pump. If the **2500 SUPREME** is turned backwards the impeller may unscrew. This will not happen in keyed models, but the packing or mechanical seal can run dry and be destroyed.

The best way to check rotation is to disconnect the coupling, but it can be checked without disconnecting the coupling. One person should be at the pump watching the shaft while a second person starts and then immediately stops the pump so the shaft barely turns over.

### **Priming The Pump**

Be sure the pump has fluid in the casing before running. If the pump is operated without fluid, the mechanical seal or packing can be destroyed in one minute. Vent air from the suction line and fill it with liquid. Start the pump with the discharge valve cracked open. After discharge pressure stabilizes, gradually open the discharge valve to the required position. If flow is lost, close the discharge valve and wait a few

seconds for the discharge pressure to build. Continued flow difficulty indicates improper pump selection or installation.

Running the pump with improper priming may destroy the sealing faces of the mechanical seal due to overheating or mechanical damage from pulsation between stationary and rotating components. Do not run the pump with the suction valve closed **AT ANY TIME!** Thermal shock can crack the stationary seat if the temperature is raised from room temperature to 250° F. in less than 30 seconds. Run the pump with the discharge valves closed only for short periods of time. The energy going into the pump heats the fluid in the casing. If the pump needs to operate shut in some of the time, be sure to install a small line (1/4 or 1/2 inch) back to the suction tank between the discharge valve and the pump for cooling.

### **Packed Pumps**

Loosen the packing on startup. The gland bolt nut should be only finger tight. New packing will expand faster with heat than older packing. Therefore, new packing must be adjusted more slowly than old packing. Too tight and it will not leak. With no cooling it will burn and be no good for sealing. **2500 SUPREME** pumps with mechanical seals have backup packing. This packing should be very loose and not tightened until seal failure occurs.

### **Mechanical Seal Pumps**

Be sure the pump is never started dry. Seal faces will gall in one minute if run dry. The backup packing is shipped in a cloth sack. Do not install the packing until the seal starts to fail. The packing can then be installed and the pump run normally until the mechanical seal is repaired.

### **Start-Up Checklist**

1. Pump rotates freely by hand.
2. Coupling aligned.
3. Oiler full and oil level correct.
4. Suction valve fully open.
5. Pump and suction line full of fluid.
6. Discharge valve is slightly open, not fully open. Fully open the discharge valve after the pump is running.

## **PART III OPERATION**

---

### **Maximum Operating Conditions**

Note: These maximum operating conditions apply to pumps which are exposed to room temperatures without external insulation.

1. Cast Iron: Maximum working pressure is 175 psig at 150° F or 150 psig at 250° degrees F. Interpolate for pressure between 150° and 250° F maximum.
2. Steel: Maximum working pressure and test pressure in accordance with ANSI B 16.5-1973, Tables 2.1 through 2.23 and Table 3.
3. For H-30 and SUPREME HARD alloy, contact HALCO distributor.
4. Cooling water through the lantern ring is required when fluid being pumped is between 150° and 250° F. In addition, it may be necessary to run water over the exposed shaft to prevent excessive heat build up at the lip seals and bearings.
5. Maximum hydraulic performance is in accordance with published performance curves.

### **Pump Records**

Maintain data cards or pump records whenever possible. This will provide ready access to information for ordering spare parts, and for evaluating pump and mechanical seal performance.

Information to be included in these records should be:

1. Pump size and serial number.
2. Pump model number, impeller diameter, and material of construction.
3. Mechanical seal manufacturer, type, code, and drawing number.
4. Motor horsepower and speed of operation.
5. Service conditions.
6. Frequency of operation.
7. Record of maintenance, including parts usage and general pump conditions.
8. Nomenclature and part number of replacement items.

On HALCO built pump packages we put a nameplate on the base with a job number. With this job number we can tell you everything about the pump package, including anything special about the motor, coupling type and size, impeller size, etc.

With this information you have much more than what is requested above

## Bearings Lubrication

### Oil Lubrication

Standard pumps have bearings OIL lubricated from the factory to lower bearing temperature and wear. There is a dipstick to check for correct oil levels. Use a good grade of 10W30 weight motor oil. Do not use a detergent oil as foaming can occur. There is also a plug on the side of the bearing frame. When adding oil, remove this plug. When oil runs out of the plug hole, the oil is at the proper level. Replace the plug. Do not overfill the oil. High levels may cause churning and overheating of the bearings. Oil should be changed every 1-2 months or 1000 hours.

### Grease Lubrication

If the pump is mounted in a vertical position or in another position which oil lubrication is not suitable, the bearing caps have been drilled and tapped for grease fittings. Grease lubrication is suitable for speeds up to 2400 RPM. However, grease normally runs hotter than oil and is more likely to contain contaminants which can damage the bearings. HALCO recommended bearing grease is Chevron Durilith EP#2 or compatible grease. Greases available in tubes are the best. Five shots with a standard hand operated grease gun of the above grease or equivalents in each bearing monthly is sufficient for twenty-four hour per day operation.

### Inboard Lip Seals Lubrication

The standard HALCO 2500 Supreme is equipped with a labyrinth seal that does not require lubrication.

Also available is a lip seal. If your pump is equipped with a lip seal the inboard bearing cover is supplied with a zerk fitting between the 9 and 10 o'clock position and a grease relief port located between the 3 and 4 o'clock position. **See Figure 3.** This is designed to create a grease barrier between the inboard lip seals. It should be greased prior to washdown and at least once a week

with five (5) shots of general purpose or water pump grease. To properly grease the lip seals, first remove the grease relief port plug (3). This allows for the removal of old grease. Apply grease at the zerk fitting (1). Old grease from the seal will be forced out of the grease relief port. Replace the grease relief port plug. Bearing lubrication plug (2) is included in the drawing for clarity.

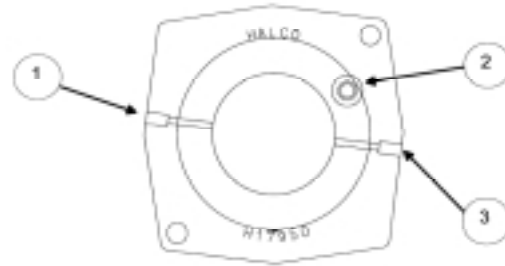

Figure 3

**WARNING! FAILURE TO REMOVE THE GREASE RELIEF PORT PRIOR TO ADDING GREASE CAN FORCE OLD GREASE PAST THE LIP SEALS AND INTO THE BEARINGS, GREATLY SHORTENING THEIR LIFE.**

### Packing Lubrication

#### Grease Lubrication

The stuffing box may be re-lubricated with grease as often as necessary to prevent the packing from overheating. It should be lubricated at least once a day. It is best to install a spring loaded grease cup (HALCO Part G1509) to automatically lubricate the packing. As you fill the grease cup a spring is compressed and a stem rises. As the grease is used the spring forces new grease to the packing and the stem lowers. When the stem is low the cup needs refilling. Grease should be pumped into the box while turning the shaft until it comes out around the packing gland (approximately 20 shots).

If the packing leakage is excessive, a thick water pump grease should be used rather than the general purpose grease. In most cases general purpose grease is acceptable.

#### Water Lubrication

It is best to inject water into the lantern ring from an external source when pumping

drilling mud. This will keep most of the solids out of the packing. PACKING AND SHAFT LIFE WILL BE INCREASED UP TO 500%. Also, water leakage from the packing will not be as objectionable as mud.

## **PART IV MAINTENANCE**

Refer to exploded diagram drawing.

### **Disassembly**

1. Loosen packing gland nuts (6B) and swing the gland bolts to the side. Remove the packing gland halves.
2. Remove the casing bolt nuts (1B).
3. Remove the casing (1).
4. Remove the impeller. **Note: The HALCO Impeller Removal Wrench, Part No. H20952 is very useful.** The wrench fits over the motor end of the shaft and key. Turn the impeller very fast. When the wrench hits the workbench and stops an impact force either tightens or loosens the impeller depending upon the direction of rotation. If you do not have a wrench, restrain the shaft at the coupling end to prevent rotation while removing the impeller. Put a block of wood against the web between impeller vanes. Hit the wooden block with a hammer to **turn the impeller counterclockwise as viewed from the suction end.**
5. Remove the stuffing box cover bolts.
6. Remove the stuffing box cover (3) from the frame by hammering on the back side of the cover in the area that the box fits into the frame. **Note: If the disassembly being performed does not require the replacement of the mechanical seal, the stationary face must not be removed from the stuffing box.**
7. Pull the packing (5) from the stuffing box bore.
8. Remove the shaft sleeve (7A). A wedge may be driven between the end of the sleeve and the shoulder of the shaft to free the sleeve. If the pump has a mechanical seal that does not need to be replaced, care must be taken to avoid damaging or dropping the rotary seal ring when removing the sleeve.

**Note: if the disassembly is being performed to replace or install a mechanical seal and/or shaft sleeve only, no further disassembly is required. See mechanical seal installation instructions below.**

9. Remove the deflector (8).
10. Remove the plug from the inboard bearing cover (10A).
11. Remove the two through bolts (12B) on the outboard bearing housing. **These are bolts threaded into the frame (9).**
12. The complete shaft and bearing sub-assembly can now be pulled from the frame.
13. Remove the outboard bearing cover (13).
14. Bend the tab on the lockwasher (14A) back and remove the locknut (14B) and lockwasher.
15. Remove the bearing housing (12) and bearings (14) from the shaft. **Note: Impacting of the entire shaft assembly against a board on the ground will remove the outboard bearing assembly.**
16. The inboard bearing (11) may now be pressed off the shaft. **Note: A piece of 3" standard wall pipe slipped over the shaft and impacted against the inner race of the bearing works exceptionally well.**

### **Inspection**

**Impeller:** Replace if impeller shows excessive erosion (especially on the pump-out vanes on the back of the impeller), corrosion, extreme wear, or vane breakage.

**Shaft:** Check for runout to see that the shaft has not been bent. If runout exceeds 0.002 inch, replace the shaft. Bearing seats and oil seal area must be smooth and free of scratches or grooves. Shaft threads must be in good condition. Replace shaft, if necessary.

**Shaft Sleeve:** Sleeve surface in the stuffing box must be smooth and free of grooves. If grooved, replace.

**Mechanical Seal:** Seal faces, gaskets, and shaft sealing members must be in perfect condition or excessive leakage may result. Replace worn or damaged parts.

**Ball Bearings:** Replace if worn, loose, or rough and noisy when rotated. New bearings

should not be unwrapped until ready for use. Replacement bearings must be of the proper size and type as supplied with the original equipment.

**Seals:** It is recommended that all O-ring and gasket seals be removed during disassembly and replaced. In those cases where new seals are not available, the old ones can be reused if they are not torn or otherwise damaged.

**General:** All parts should be clean before assembly. This is especially important for retaining rings and O-ring grooves, threads, gasket surfaces, bearings, and bearing surfaces. Any burrs should be removed with crocus cloth.

## Assembly

Numbers following part names refer to the part as shown on the exploded view drawing.

### A. Shaft And Bearing Sub-Assembly

**Note: Installation of the bearings with a press is an acceptable substitute for the following method. Apply the load to the inner race only when pressing the bearings onto the shaft.**

1. Heat the bearings to 300° F. **Note: One-half hour in an oven at 300° F. will work nicely.**
2. Slip large double row inboard bearing (11) onto the shaft. **Caution: Bearings must shoulder against the shaft.**
3. With the bearing housing seal (12A) in place, slide the bearing housing (12) onto the shaft from the coupling end. The large O.D. of the bearing housing should be facing the coupling end.
4. Slip the outboard bearings (11) onto the shaft. **Note: Outboard bearings are to be mounted back-to-back (that is, the sides of the bearings with the manufacturer's name and the bearing number are placed together). Improper bearing orientation will result in bearing failure. Check the installation requirements provided with the pump, and the markings on the bearings to help identify the "back-to-back" arrangement. Caution: Bearings must shoulder against the shaft.** Allow the bearings to cool. With lockwasher (14A) in place,

tighten locknut (14B) with the bevel positioned against the bearings. Tighten the locknut to 250 ft./lb. of torque. Bend one tab of the lockwasher into the nut.

5. IF grease lubrication is being used rather than oil, pack the bearings (11 & 14) full with grease, preferably Exxon Unirex N@ or any of the other recommended greases.
6. Grease or oil the outboard bearing (14) O.D's and pull the bearing housing over them into place. The outer races may be pushed in with a hand push or with a light tapping **applied only to the outer race.**
7. Install lip seal (13C) in outboard bearing cover (13) with the lip aimed in toward the bearings. Generously lubricate the rubber lip and the shaft in the sealing area. Fill the space behind the lip on the seal and half of the bearing cover with grease.
8. Put cover seal O-ring (13B) in place. Slide the outboard bearing cover over the shaft. **Caution: Be careful not to cut the oil seal on the edge of the shaft keyway.** Secure over two bolts (13D) and tighten evenly to approximately 20 ft./lb. of torque.

### B. Power Frame Sub-Assembly

1. Install inboard bearing cover seal (10C) into the inboard bearing cover (10) flush with the backside of the cover. Install exclusion seal (10F) flush with the outside of the cover. **The sealing lips on both seals should be pointed outward (away) from the bearings for grease lubrication, while the lip of (10C) points inward for oil lubrication.** Pack the area between the lip seals full with grease. Using grease to hold it in place, put the inboard bearing cover gasket (10B) on the cover.
2. The bores of the bearing frame must be clean. Lightly oil the bores to facilitate the insertion of the bearing train. Insert the shaft and bearing sub-assembly into the frame (9) until the threaded end of the shaft extends approximately halfway into the drip pan area.
3. The bearing train will slip in relatively easy by pushing the coupling end with one hand and pulling the opposite hand



with the other. A rubber mallet may be used to pound on the end of the shaft assembly to help it align. **DO NOT USE EXCESSIVE FORCE.** If installation is difficult it indicates lack of concentricity between the bearings and frame. Excessive pounding will damage the bearings.

4. Slip inboard bearing cover assembly (10A) over the end of the shaft. Continue installing the shaft and bearing assembly in the frame until the gap between the frame and outboard bearing housing flange is approximately ¼ inch.
5. Install two bolts (12B-1/2D x 1-1/2 inch) with jam nuts (12C) in the threaded holes in the bearing housing. Install the remaining two bolts (12B) through the unthreaded holes in the bearing housing and thread them into the frame. **Do not tighten any bolts.**
6. Bolt the inboard cover to the frame with bolts (10D-3/8D x 1-1/2 inch) and nuts (10E).
7. Lubricate I.D. of deflector (8). Slip the deflector on the shaft with the cup side facing away from the bearing cover.
8. Slip shaft sleeve seal (7C) onto the shaft and push it to the shoulder where the seal will seat. For pumps with a mechanical seal, see mechanical seal installation instructions on the next page for assembling the remainder of the pump.
9. The sleeved area of the shaft must be lightly coated with an anti-seize compound before installing the sleeve. Install sleeve (7A) with a twisting motion to spread the anti-seize compound. The gap between the sleeve and the shaft shoulder will be approximately 1/32 inch.

#### **C. Assembly Of The Fluid End To The Power Frame**

1. Lubricate the inside of the frame where the stuffing box cover slips in with an anti-seize compound. Install stuffing box cover (3) and secure with two bolts (3A-1/2D x 1-1/4 inch)
2. Lubricate the shaft threads and the face of the shaft sleeve with an anti-seize compound. Wash the O-ring with clean shop solvent and pat dry with a clean cloth. Install the O-ring into the impeller

(2). Thread the impeller with impeller seal O-ring onto the shaft. Tighten to approximately 160 ft./lb. of torque.

3. Loosen the two through bolts (12B).
4. Draw the bearing housing rearward with the jam bolts (12B) while rotating the impeller. Stop when the impeller just touches the stuffing box cover.
5. Bring the through bolts up finger tight.
6. Loosen the jam bolts.
7. Tighten the through bolts until a clearance of 0.020 inch exists between the impeller back vanes and stuffing box cover (3). A hacksaw blade is approximately 0.020 inch thick and can be used as a gauge when no better tooling is available.
8. Advance both jam bolts until they touch the frame finger tight, then tighten the jam nuts (12C).
9. Now tighten the through bolts down evenly. Rotate the shaft. **The impeller should turn freely without rubbing.**
10. Install casing gasket (1A). Hold in place with grease if necessary.
11. Apply a coat of anti-seize on all of the stuffing box cover diameters.
12. Install casing (1) on the frame using studs (1C) and nuts (1D). Put a small quantity of anti-seize compound on the threads on the nut end of the studs. Tighten the nuts to 140 ft./lb. of torque using a criss-cross tightening pattern.

#### **D. Packing The Pump**

1. Make sure the box is cleaned of all old packing and the plastic lantern ring.
2. Bend a wire and pull it down the shaft or shaft sleeve to ensure it is smooth for good packing life.
3. Grease all five shaft packing rings (5). Insert three packing rings alternating the splits in the rings from top to bottom starting with the split on the first ring on the bottom. If King type packing is being used (Figure 8), the rings should be installed with the lips toward the impeller.
4. Install the lantern ring with the split in the vertical position. The two halves of the packing gland (4) may be used to push the packing and the lantern ring together and to the bottom of the box.
5. Insert the final two packing rings. The objective is to have the last split down so that leakage will drip down and not

have to go over the shaft and possibly in the bearings. If King packing is being used, insert the final King ring with the lip towards the outside and split on top, and follow with the single ring of square packing split down.

6. With the packing gland (4) in position, swing the gland bolts into place. Initially tighten the gland hard to compress the packing. Then back off the gland bolts and retighten only finger tight. **Caution: Tighten the gland against the packing finger tight only. If packing is over-tightened it may be burned when the pump is started.**

## E. Mechanical Seal Assembly

### Changing the H22451-1 Mechanical Seal

1. If the impeller and/or stuffing box are being replaced adjust the impeller clearance BEFORE installing the seal. Back the through bolts (12B) out approximately ¼ inch. Tighten the jam bolts (12B) until a clearance of 0,015-0.020 inch between the back of the impeller (2) and the stuffing box (3) is obtained. Alternately tighten the through bolts and jam bolts making sure that the clearance set above is maintained. Tighten the jam nuts and recheck the clearance.
2. Make sure the shoulder where the stationary will sit and the inside of the stuffing box (3) is clean and that the 30° bevel on the 3-3/8 inch I.D. is free from burrs and sharp edges. Coat the I.D. of the stuffing box stationary seat packet with oil. Place the stuffing box on a table or other flat surface with the impeller side facing up.
3. The slotted side must be installed away from the impeller or down when the stuffing box is positioned as described in step 2 (above). Coat the O.D. of the stationary seat and O-ring with a thin film of oil.
4. Carefully install the stationary seat into the stuffing box. Be sure the groove of the stationary fits properly over the drive pin. Be sure that the stationary seats evenly against the stuffing box shoulder. **Hint: Wrap the end of a wooden hammer handle with a rag. Press firmly on the face of the stationary. Do not strike. Push gently on one side, alternating sides until the stationary is completely down.** Coat the stationary seat face with light oil, then wipe off the majority of the oil with a clean cloth, leaving only a light film.
5. Lubricate the inside of the frame (9) where the stuffing box (3) slips in with an anti-seize compound. Install the stuffing box and secure with bolts (3A-1/2D x 1-1/4 inch). Care should be taken to prevent bumping of the stationary seal on the shaft end.
6. Remove the rotating seal ring (4A of Figure 9) if it is not glued into position and store it in a safe place. Gluing can be determined by pulling on it gently. Coat the O.D. of the shaft sleeve (7A) and the I.D. of the rubber bellows (Item 4B of Figure 9) with a thin coat of oil.
7. Place the sleeve (7A) with the impeller end up on a table. The impeller end is the end with the smallest I.D. With the sealing face of the rotary unit facing down and the rubber end up, gently ease the rubber bellows over the sleeve and push it to the bottom half of the sleeve. (It is not necessary to push it all the way to the bottom). If the rotating seal ring (4A) has been removed, lightly coat the face of the bellows (Item 4B of Figure 9) with grease. (This is necessary to hold the rotating seal ring in place during assembly). Reinstall the rotating seal ring into the cage assembly (Item 4C of Figure 9).
8. Make sure no foreign material is present on the seal faces. Make sure the shaft (7) is free of nicks and burrs and is clean and dry. The sleeve area of the shaft, the shaft threads and the shaft face must be lightly coated with anti-seize compound before installing the sleeve (7A). Install the sleeve with a twisting motion. As the seal faces make contact, continue to push the sleeve through the I.D. of the rotary seal element until the gap between the sleeve and the shaft shoulder is approximately 1/32 inch.
9. Install the spring retainer (Item 9 of Figure 9) and the impeller O-ring (2A) in its groove and coat with anti-seize compound. Place the mechanical seal spring (Item 6 of Figure 9) over the

- rotary unit of the seal (which is inside the stuffing box cover).
10. Thread the impeller (2) onto the shaft (7). Be sure that the spring engages in the retainer on the impeller. Tighten to approximately 60 ft./lb. of torque.
  11. Install the casing gasket (1A). Hold it in place with grease if necessary. Apply a light coat of anti-seize compound on the 14-1/8 inch diameter of the stuffing box cover. Install the casing on the frame using studs (1C) and nuts (1B). Put a small quantity of anti-seize compound on the threads on the nut end of the studs. Tighten the nuts to 140 ft./lb. of torque using a criss-cross tightening pattern.
  12. We recommend that the three shaft packing rings (5) are not installed until the seal fails. The rings are for emergency backup until the mechanical seal can be replaced. When they are installed, first grease them. Insert all packing rings alternating the splits from top to bottom starting with the split on the first ring at the bottom.

2. Place the impeller suction side down and hub side up.
3. Lubricate the inside of rubber bellows of the seal. Firmly slide the entire rotating seal assembly onto the impeller hub until the rubber bellows butts against the back of the impeller.
4. Make sure no foreign material is present on the seal faces.
5. Thread the impeller (2) onto the shaft (7). Tighten to approximately 160 ft./lb. of torque. It is easiest with a HALCO Impeller Wrench (Part H20592).
6. Install the casing gasket (1A). Hold it in place with grease if necessary. Apply a light coat of anti-seize compound on the 14-1/8 diameter of the stuffing box cover. Install the casing (1) on the frame using studs (1C) and nuts (1B). Put a small quantity of anti-seize compound on the threads on the nut end of the studs. Tighten nuts to 140 ft./lb. of torque using a criss-cross tightening pattern.

### Packing Leakage And Rapid Packing Wear

Most early packing failures are caused by over-tightening or poor installation.

### Packing Appearance

If the packing being removed is hard and brittle, it has been run dry some time in its life. This is often done in the first hour of service. The packing has more ability to grow with heat during its early life. Even if the packing is adjusted just right before starting the pump, in the first few minutes of operation the packing will grow with heat and become over-tight. It will then run drop-tight and the packing will burn. ONCE THE PACKING IS BURNED IT WILL NEVER SEAL PROPERLY AGAIN. Let new packing leak more in the first few hours and then adjust it to 10-12 drops per minute.

### Installing Water Flush System To Be Acceptable By Oil Companies

Many oil operators will not allow water to be put on the packing because of excess water getting into the mud, a result of poorly designed and maintained systems. Two major problems cause this complaint:

1. Too much line pressure

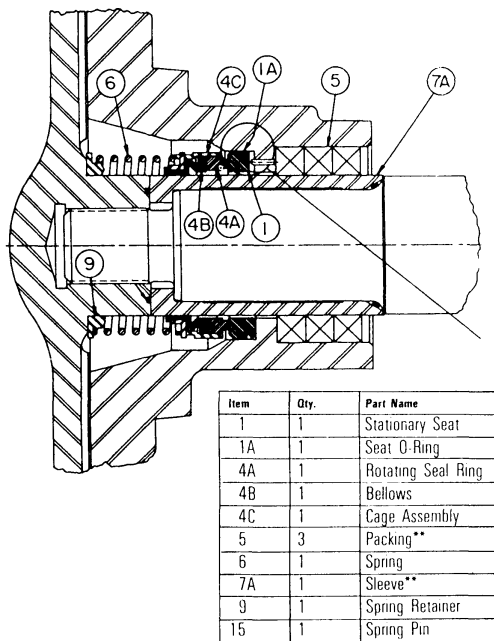

\*\*These items are not included with seal

Figure 9

### Changing The H25001-1 Mechanical Seal

1. Follow steps 1 through 5 above to install the stationary.

2. Not turning water off when pump is not in use.

### **Controlling Water Pressure To The Packing**

The water pressure is usually too high. The brake cooling pump is normally used which operates at pressures from 50 to 75 psi. Only 5 to 10 psi water is needed to cool and lubricate the packing. A pressure regulator should be installed to reduce the pressure on the packing. One regulator can supply all centrifugal pumps from a central system.

### **Controlling When To Use Water On Packing**

LARGE VOLUMES of water get into the mud when the pump is NOT OPERATING. When the pump is running, the shaft deflects and when stopped, the shaft straightens up and a gap occurs down one side of the shaft between the packing and the shaft. This allows a stream of water to enter the mud. You can manually turn off the water when the pump is shut down but a better way is to install a solenoid valve in the water supply line that turns the water on and off as the motor is turned on and off. ONLY a small amount of water (a few drops per minute) which gets into the mud while the pump is running should not be objectionable to the oil companies.

### **Bearing Failures**

**Except for cavitation problems, bearing failure is the greatest cause of increased pump operating cost.** If you continue to run a pump when bearing failures occur, there is an excellent chance the entire pump will be destroyed. Therefore it is very important to change the bearings when failure **starts**. If you wait for complete failure other fluid end parts will be damaged. Bearing failure is more often caused by **lubrication failure** than by normal bearing wear.

### **Misalignment Between Pump And Driver**

A major cause of bearing failures is misalignment. Alignment between the pump and motor should always be checked after shipment and periodically rechecked.

### **Detection Of Bearing Failure When Pump Is Running**

The first indication of lubricant and bearing failure is a rapid rise in operating temperature. You should feel the frame once a week to get a feel for how hot the bearings normally run. A sudden high increase in temperature normally means the bearings are beginning to fail and need changing.

You cannot hold your hand for very long on unsatisfactory temperatures. If you can keep your hand on the housing for 5 seconds the temperature is about 160° F. which is suitable for most pumps. If you cannot hold your hand on the housing for five seconds or if the bearing housing is so hot you do not want to touch it, there is most likely lubricant and/or bearing failure.

## **PART V MISCELLANEOUS INFORMATION**

---

### **OPERATING LIMITS OF RIG CENTRIFUGAL PUMPS**

As with any type of equipment, centrifugal pumps have operating limits. Observing these limits will extend the life of your pumps.

### **Suction Line Velocity**

Suction line velocity should not exceed 10 feet/second for reasonable pump life. This means the maximum flow for a 6 inch suction is 900 GPM and an 8 inch suction is 1600 GPM. If you want to flow more than 1600 GPM a 10-inch or larger suction line should be installed.

### **Net Positive Suction Head (NPSH)**

The system must have enough NPSH for the pump requirements or the pump will cavitate, greatly reducing its life.

It appears that most installations do not have enough NPSH to run a 5x6 pump at flows above 1400GPM even with an 8-inch suction. (This does not mean that no one has enough NPSH). The result of inadequate NPSH is cavitation and early pump failure. Through observation, the greatest problem with NPSH is encountered with mud mixing pumps. Most companies do not change the nozzles in their mud guns

often enough. On a 1-inch nozzle, 1/16 inch wear per side will increase flow by 26%.

Example: Volume required increases from 1500 GPM to 1890 GPM. A wear of 1/8 inch increases flow by 56% (from 1500 GPM to 2340 GPM). If sized correctly when new, the mud mixing pumps will soon be required to furnish a greatly increased volume and perhaps more than the maximum limit of the pump. We have found customers running 6x5 pumps on mud mixing experiencing much higher operating costs than those running 8x6 pumps. Companies running 6x5 pumps at 1750 RPM on mud mixing often have high maintenance every six months, while customers running 8x6 pumps at 1150 RPM often do not require major repair for two years. Looking at the failures, it appears the problem is inadequate NPSH at higher volumes, most likely caused by nozzle wear (HALCO manufactures rubber mud gun nozzles to prevent most of the wear). At 1500 GPM a 6x5 pump at 1750 RPM requires up to a 26 foot NPSH while a 6x8 pump at 1150 RPM requires only a 7-foot NPSH. Nearly every system will have a 7-foot NPSH available while almost no system will have a 26-foot NPSH available, especially if the mud temperature exceeds 140° F.

We normally do not see cavitation as much with the desander and desilter pumps because the rubber cones do not wear as rapidly as steel cones. Volume requirements are closer to 800 to 1000 GPM.

**Capacity limits for pumps listed below do not consider suction line velocity or NPSH calculations which must be made for every installation.**

PUMP SIZE	MAXIMUM GPM
3x2x13	450
4x3x13	750
5x4x14	1100
6x5x14	1800
8x6x14	2400

### Capacity Requirements Of Equipment In Rig Applications

The chart below lists the normal design requirements when the equipment is new with no wear.

EQUIPMENT	DESIGN VOLUME
4" CONE	45 to 60 GPM
4H (5") CONE	80 GPM
6" CONE	125 GPM
8" CONE	250 GPM
12" CONE	450 to 500 GPM
6" MUD HOPPER	550 GPM
¾" NOZZLE	80 GPM
1" NOZZLE	140 GPM
1 ½ " NOZZLE	300 GPM
2" NOZZLE	550 to 600 GPM
MECHANICAL BRAKES	40 to 50 GPM
ELECTRIC BRAKES	50 to 200 GPM
SWACO DEGASSER	400 GPM
WELCO DEGASSER	700 GPM
BRANDT DG5 DEGASSER	500 GPM
BRANDT DG10 DEGASSER	1000 GPM

### Long Term Pump And Motor Storage

Pump packages should be stored indoors in a clean, dry and protected environment.

1. The storage area is to be free from any vibration and temperature extremes.
2. Motor and pump shafts are to be rotated manually every two months. A record of the rotation should be made.
3. Grease in the motor and the pump bearings is to be purged at the time of removal from storage and replaced with an ample supply of fresh grease in each grease cavity.
4. Motor windings should be megged at the time the equipment is placed in storage. At the time of removal from storage the resistance reading must not have dropped more than 50% from the initial reading. Any drop below this point necessitates electrical or mechanical drying of the motor windings. Condensation from hot days and cool nights can fill the motor half full with water. This is a greater potential problem in damp areas.
5. If the pumps are to be stored outdoors, the pump suction and discharge openings should be sealed to prevent any water from entering the pump housing. This will prevent rust and corrosion.

## 2500 SUPREME SPARE PARTS LIST

DRAWING BELOW

ITEM	QTY.	PART NUMBER	PART NAME	MATERIAL
1	1	SEE NEXT PAGE	CASING + ITEM 1A-1E	HARD IRON
1A*	1	H10399-46-1	GASKET, CASING	FIBER
1B	12	H3932-61	NUT, CASING STUDS	STAINLESS, 3/4-10 HEX HEAD
1C	8	H2507-3	STUD, CASING	STEEL, 3/4-10 X 3-1/4" LONG
1CA	4	H3862-76	STUD, CASING	STEEL, 3/4-10 X 3" LONG
1D	1	SEE NEXT PAGE	CASING LESS WEAR PAD KIT	HARD IRON
1E	1	SEE NEXT PAGE	WEAR PAD	HARD IRON
2	1	SEE NEXT PAGE	IMPELLER	HARD IRON
2A*	1	H19110-72	SEAL, IMPELLER	VITON
3	1	H22223-01-30A	STUFFING BOX COVER, SEAL	HARD IRON
3	1	H20614-01-30A	STUFFING BOX COVER, PACKED	HARD IRON
3A	2	H3861-117	BOLT, STUFFING BOX	STEEL, 1/2-13 X 1-1/4"
4	1	H20622A	GLAND SET	300 STAINLESS STEEL
5	1	H8264-24-1A	PACKING 5 RINGS & LANT. RING	GRAPHITE ASBESTOS
5A	1	H2537-24A	PACKING 3 RINGS FOR SEAL	GRAPHITE ASBESTOS
6	2	H3701A	BOLT, GLAND ASSEMBLY	300 STAINLESS STEEL
7	1	H20612-02-33	SHAFT	4140
7A	1	H20613-21G-7A	SLEEVE, SHAFT	416 SS, CERAMIC COATED
7B	1	H4372-5-21	KEY, COUPLING END	416 STAINLESS STEEL
7C*	1	H7496-236	SEAL, SHAFT SLEEVE	BUNA-N
8	1	H22210-1	DEFLECTOR	RUBBER
9	1	H17444	FRAME	CAST IRON
9A	2	H2538	JACK BOLTS	STAINLESS STEEL
10A	1	H17950	COVER, INBOARD BEARING	CAST IRON
10B*	1	H20625	GASKET, INBOARD BRG. COVER	ASBESTOS
10C*	1	H20619-01	OIL SEAL, INBOARD BRG. COVER	BUNA-N
10D	2	H3861-1	BOLT-INBOARD, BEARING COVER	STEEL, 1/2"-13 X 1-1/2" LONG
10F*	1	H20620-01	EXCLUSION SEAL, INBD. BRG.	BUNA-N
11	1	H20615-1	BEARING, INBOARD	FAFNIR 5313 WBR., MRC5313
12	1	H20624-01-01	HOUSING, OUTBOARD BEARING	CAST IRON
12A*	1	H7496-253	SEAL, BEARING HOUSING	BUNA-N
12B	4	H3861-138	BOLTS, BEARING HOUSING	STEEL, 1/2"-13 X 1-1/2" LONG
12C	2	H3932-62	NUTS, BEARING HOUSING	300 S.S.1/2-13 JAM NUT
13	1	H20617-01-01	COVER, OUTBOARD BEARING	DUCTILE IRON
13B*	1	H7496-26	SEAL, OUTBOARD BRG. COVER	BUNA-N
13C*	1	H20619-02	OIL SEAL, OUTBOARD BRG. CVR.	BUNA-N
13D	2	H3861-139	BOLT, OUTBOARD BRG. COVER	STEEL, 3/8-16 X 1" LONG
14	2	H20616-1	BEARING, OUTBOARD	FAFNIR 7311 PW-BR-SU, MR731
14A*	1	H6124-4	LOCK WASHER, BEARING	SKF-W1" (STEEL)
14B*	1	H6123-4	LOCK NUT, BEARING	SKF-N1" (STEEL)
15	1	H2539	DIPSTICK	RUBBER AND STEEL
16	1	H8267-1	BREATHER	STEEL
16A	2	H8505-1	PLUG, OIL	STEEL
17	1	H22451-1A	MECHANICAL SEAL	TUNGSTEN CARBIDE

## CASINGS, IMPELLERS AND WEAR PADS

ITEM	QTY.	PART NUMBER	PART NAME	MATERIAL
1-1	1	H19203-01-30A	3 X 2 X 13 CASING	HARD IRON
2-1	1	H2521-XX-30	3 X 2 X 13 IMPELLER	HARD IRON
1-2	1	H19205-01-30A	4 X 3 X 13 CASING	HARD IRON
1E-2	1	H2501-01-30A	4 X 3 X 13 CASING WEAR PAD	HARD IRON
2-2	1	H2522-XX-30	4 X 3 X 13 IMPELLER	HARD IRON
1-3	1	H19222-01-30A	5 X 4 X 14 CASING	HARD IRON
1E-3	1	H2502-01-30A	5 X 4 X 14 CASING WEAR PAD	HARD IRON
2-3	1	H2523-XX-30	5 X 4 X 14 IMPELLER	HARD IRON
1-4	1	H19122-01-30A	6 X 5 X 11 CASING	HARD IRON
1E-4	1	H2503-01-30A	6 X 5 X 11 CASING WEAR PAD	HARD IRON
2-4	1	H2524-XX-30	6 X 5 X 11 IMPELLER	HARD IRON
1-5	1	H19123-01-30A	6 X 5 X 14 CASING	HARD IRON
1E-5	1	H2504-01-30A	6 X 5 X 14 CASING WEAR PAD	HARD IRON
2-5	1	H2524-XX-30	6 X 5 X 14 IMPELLER	HARD IRON
1-6	1	H19763-01-30A	8 X 6 X 11 CASING	HARD IRON
1E-6	1	H2505-01-30A	8 X 6 X 11 CASING WEAR PAD	HARD IRON
2-6	1	H2524-XX-30	8 X 6 X 11 IMPELLER	HARD IRON
1-7	1	H19117-01-30A	8 X 6 X 14 CASING	HARD IRON
1E-7	1	H2506-01-30A	8 X 6 X 14 CASING WEAR PAD	HARD IRON
2-7	1	H2525-XX-30	8 X 6 X 14 IMPELLER	HARD IRON

## KITS

*KITS	COMPONENTS	KIT NUMBER	KIT NAME
	1A, 2A, 7C	H10399-46-1A	FLUID END GASKET KIT
	10B, 12A, 13B	H20625A	POWER END GAKET KIT
	10C, 10F, 13C	H20619A	GREASE SEAL KIT
	14A,14B	H6123-4A	LOCKNUT KIT
<b>SPECIAL TOOLS:</b>		H20952	IMPELLER REMOVAL TOOL

